



Industrial Encoders  
Direct Ltd

# LINEAR ENCODERS

## MLS-3

*Magnetic Incremental Technology*



*Measuring Scale with Guidance Profile & Guided Sensor Head*

### Features

- Resolution up to 0,001 mm
- Requires no cleaning or maintenance
- Stainless Steel cover protection
- Shielded metal enclosure
- Easy mounting (glues into place)
- Contact-less and wear free system
- Resistant to vibration & Shock
- IP67 Protection
- Resistant to humidity
- High accuracy (+/- 5 micron)
- Highly reliable
- Measuring lengths up to 4M
- Connection cable up to 20M
- Signal processing incorporated

### Key advantages of the MLS-3 Magnetic Linear Encoder Scale

- The compact scanning unit is self-guided along the scale.
- Long-life linear motion guide bearing system.
- The scale, scanning unit and guide are protected against contamination by an aluminum extrusion and elastic sealing lips.
- Coupling elements between scanning carriage and transfer web are designed to transfer motion only in the measuring direction.
- Motion, including pitch of the connecting web in a direction perpendicular to the measurement is compensated without affecting accuracy.
- Contact-less and wear-less linear position measuring system.



### Typical Applications

- Machining centers
- Lathes
- Milling machines
- Drilling machines
- Grinding machines
- Electrical discharge machines
- Sheet metal working machines
- Welding machines
- Bending presses
- Robotics/materials handling
- Linear units/linear drives
- Linear guides
- Marble Machines
- Wood Cutting Machines
- PVC Profile Cutting Machines
- Glassworking machinery etc.
- Measuring machines

The MLS-3 Sealed linear encoder is ideal for applications requiring measurement of length with high accuracy and resolution in harsh environments with the presence of airborne liquids and particles such as coolants, lubricants, chips and swarf.

### Magnetic Tape Complex Structure



*Strontium ferrite bonded into a plastic or rubber (elastomer) matrix bonded onto a steel support. This is then incorporated into the PS2 Profile system.*

### Industrial Encoders Direct Limited

TEL: (UK) +44 (0) 1978 664722

FAX: (UK) +44 1978 664733

WEB: [www.industrialencodersdirect.co.uk](http://www.industrialencodersdirect.co.uk)

EMAIL: [sales@industrialencodersdirect.co.uk](mailto:sales@industrialencodersdirect.co.uk)

All information shown shall under no circumstances form part of any contractual representation by Industrial Encoders Direct Ltd. All information is issued for guidance purposes only.  
A copy of our Standard Terms and Conditions is available on request.

## Magnetic Tape Mechanical Properties

### Mechanical properties

Width	5 mm
Thickness	1,2 mm
Length	Up to 100 m
Number of tracks	1
Pole pitch	1 mm, 2 mm, 5 mm
Absolute pole pattern possible	yes

## Magnetic Tape Environmental Properties

Operating temperature	-40°C to +120°C
Storage temperature	-40°C to +120°C
Water Protection	CrNi 17 7 stainless steel carrier nitrile rubber high temperature magnetic tape

## Technical Specifications

Resolutions: (µm) 1, 5, 10, 25, 62.5, or 1mm (with 4x triggering)  
 Connections: Up to 100 m. Cable length on request  
 Allowable Head Gap: Up to 2.5 mm (Depend on pole pitch)  
 Magnetic Tape Type: B5 high temperature magnetic tape  
 Measure Accuracy: +/- 5 micron  
 Linear Expansion Coefficient:  $(11\pm 1) \times 10^{-6} / K$   
 Protection Class: IP67

Output signals: A, /A, B, /B, (Z, /Z option)  
 Input current: Max. 40mA per Channel  
 Power supply: 10...30VDC or 5VDC  
 Housing Material: Aluminium  
 Travel velocity: 3 m/s  
 Repetability: ±1 increments  
 Temperature range: -25 +85 °C

## Mechanical Dimensions

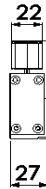
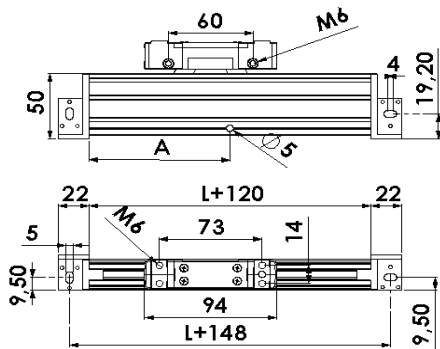

MLS-3 Sealed Magnetic Measuring Scale system consists of a slide carrier determining position with sealed rugged aluminium profile. It operates without friction. The scanning head and scale are adjusted to each other during mounting. The sealed linear encoder is protected from dust, chips and splash fluids making it ideal for operation on machine tools.

An aluminium housing and elastic sealing lips protect the magnetic tape, scanning carriage and guideway from chips, swarf, dirt and splashwater. The scanning carriage travels in a low-friction guide within the scale unit. It compensates unavoidable misalignment between the scale and machine guideways. MLS-3 Sealed Magnetic Measuring Scale can be suitable many installation conditions.

## Ordering Codes

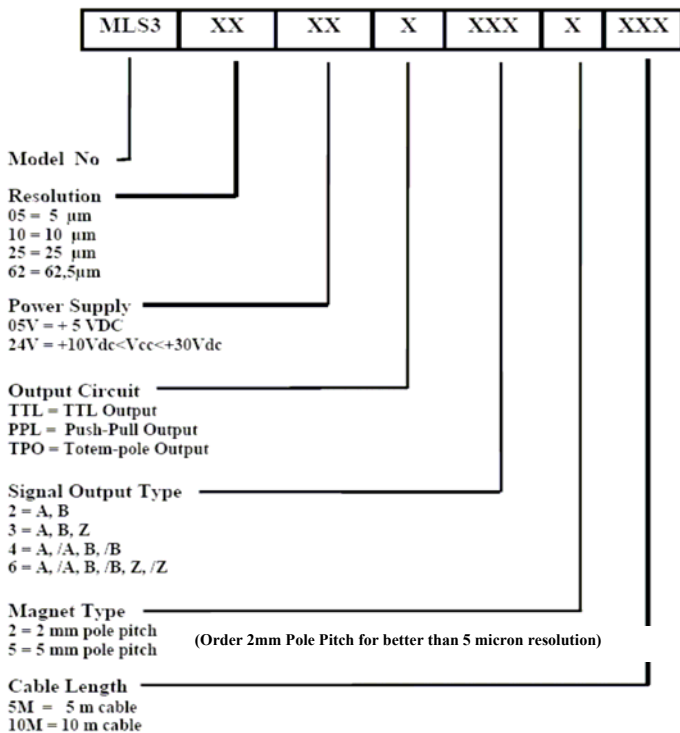

"The MLS-3 is suitable for applications where other measuring systems simply are not"

## Waveform Diagram

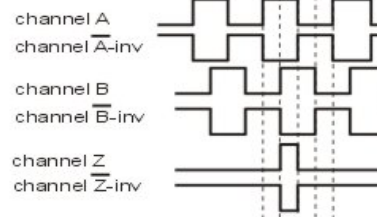

## Connections

Function	Colour	Pin
A	Yellow	1
B/	White	2
+V	Red	3
0V	Black	4
A/	Blue	5
B	Green	6
Z/	Grey	7
Z	Orange	8
Ground	Shield	9